

ELEVATION

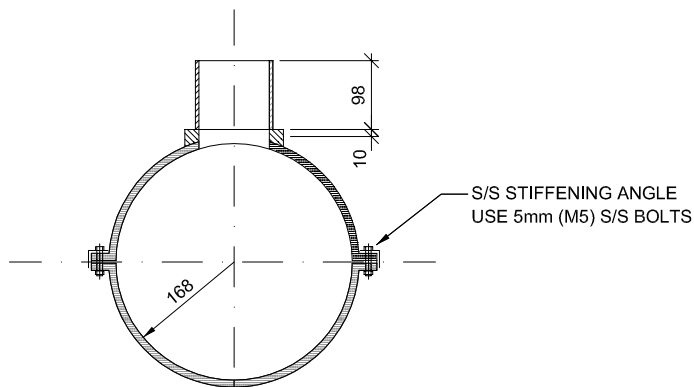

SECTION A-A

INSTALLATION

1. Scrape host pipe, all loose material to be removed.
2. Clean mating surfaces with Isoprophyl Alcohol.
3. Clamp on junction fitting in desired position.
4. Connect electrodes and activate controller.
5. Apply heat for 120 seconds.
6. Allow to cool for 10 minutes, leaving electrodes in place.
7. Remove electrodes.
8. Install removable plug in branch and apply test head of 2 m.
9. Using a hole saw, drill out a 100mm dia hole in pipe wall, remove swarf and smooth any rough surfaces with amery paper.
10. Installation of electrofusion junction shall be carried out by certified welders only.

NOTES:

1. Material of junction: PE80 SDR17
2. S/S Components: Grade 304
3. Pressure Rating: 12.5 Bar
4. Size: 160 x 110 mm (ID of branch <100 mm)
5. Suppliers Name: Prebensen Pipelines Ltd.



STANDARD DETAIL:

**ELECTROFUSION JUNCTION
160 x 110MM SADDLE
WITH UNDER PART**

DATE: June 2010
NOT TO SCALE

TCDC NO:

SHEET NO:

REV:

5000

10